

Product information

Gas pressure regulators and gas filters

February 2019



Truma gas pressure regulators

Compact, light, user-friendly

In order to meet market demand, Truma has improved its gas pressure regulators. The new generation is especially compact and light. The crash sensor has also been optimised: if the regulator is triggered, this can be seen on the yellow button. The gas pressure regulators with crash sensor (CS) and yellow button can also be used while the vehicle is in motion. All variants without CS may be used only when the vehicle is stationary.

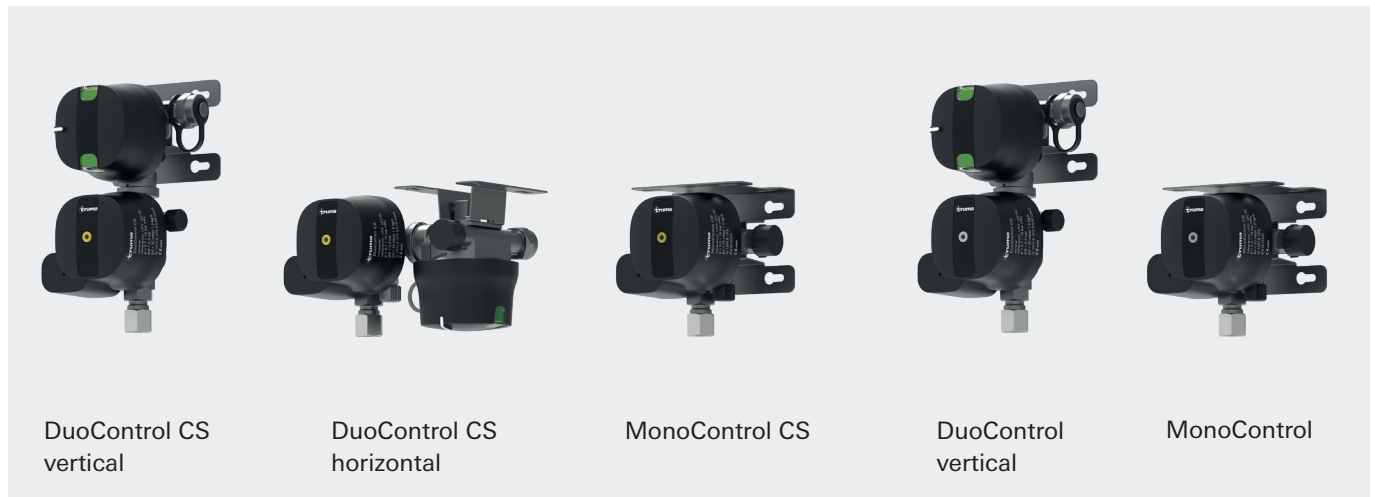

DuoControl (CS) vertical and horizontal

- **Compact:** A 40 % reduction in construction volume allows more scope for design.
- **Convenient:** Clear status display of the operating cylinder (empty/full).
- **Light:** Lightweight.

MonoControl (CS)

- **Compact:** A 35 % reduction in construction volume allows more scope for design.
- **Practical:** One single variant simplifies handling.
- **Light:** 40% less weight than the previous model.

Variants with crash sensor

DuoControl CS vertical
DuoControl CS horizontal
MonoControl CS

Variants without crash sensor

DuoControl vertical
MonoControl

Gas filter

The Truma Gas filter effectively protects your gas system against contamination: oily residues are reliably filtered out of the gas flow. They accumulate in a filter pad at the bottom of the filter bowl, which is easy to replace when the cylinder is replaced.

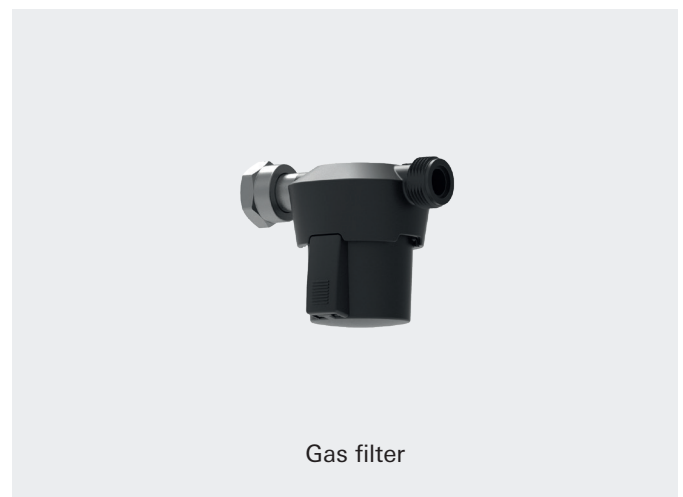

Please note:

Truma will not accept warranty claims for gas pressure regulators that have been used without a gas filter and that break down due to oiling.

- **Compact:** Because of its low design, it fits in almost every gas cylinder box.
- **Effective:** Filters up to 99.9% of the aerosols and protects the gas system and all gas appliances.
- **Simple:** Easy to retrofit.

Technical data

DuoControl (CS) vertical and horizontal, MonoControl (CS)

Gas type: LP gas (propane / butane)

Admission pressure: 0.7 - 16 bar DuoControl (CS),
0.3 - 16 bar MonoControl (CS)

Output pressure: 30 mbar

Regulator output: 1.5 kg/h

Regulator inlet: Male thread M20 x 1.5 (G.13)

Regulator outlet: Olive screw connection 10 mm
or 8 mm (H.9)

Horizontal triggering value (only CS): 3.5 g ± 0.5 g

Weight: 900 g DuoControl (CS),
500 g MonoControl (CS)

Gas filter

Gas type: LP gas (propane / butane)

Inlet: Male thread M20 x 1.5 (G.13)

Outlet: Union nut M20 x 1.5 (H.20)

Weight (incl. filter pad): 370 g

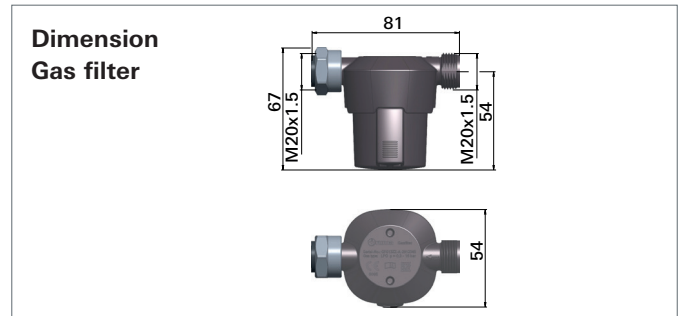
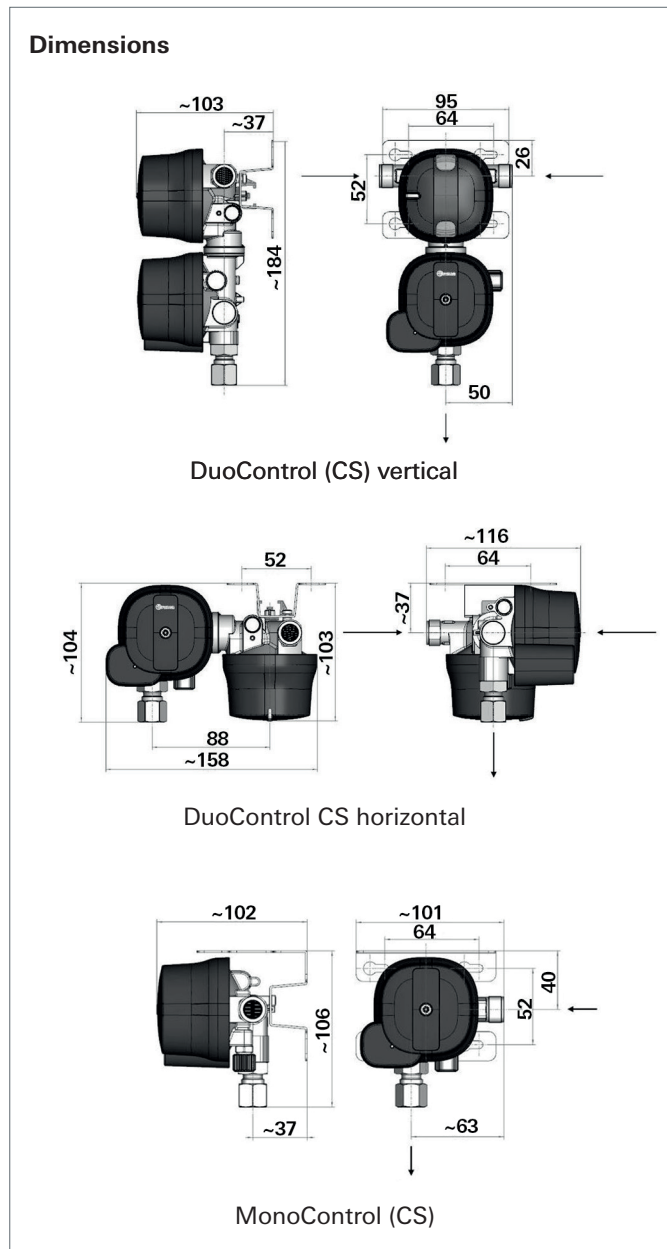

Truma high-pressure hoses

With hose rupture protection (HRP) for maximum safety while driving. If the hose is damaged, the hose rupture protection trips and stops the flow of gas. The variants without HRP are suitable only for stationary operation.

Most common gas cylinder-connection in the countries:

G.12 DE, AT, FI, PL

G.7 GB, IE

G.2 CH, FR

G.1 IT, MT, CY, GR, TR

G.10 SE, NO, IS, PT

G.8 GB, IE, ES, BE, NL, DK, NO, HR, CZ, SI, SK, HU

Truma high-pressure hoses with HRP, 450 and 750 mm





	450 mm	
	SP*	BPK 12**
G.12	50415-01	50415-11
G.7	50415-02	50415-12
G.2	50415-03	50415-13
G.1	50415-04	50415-14
G.10	50415-05	50415-15
G.8	50415-06	50415-16
750 mm		
G.12	50425-01	50425-11
G.7	50425-02	50425-12

Truma high-pressure hoses without HRP, 450 mm

	SP*	BPK 12**
G.7	50405-02	50405-12
G.8	50405-06	50405-16

* Single pack, ** Bulk pack (12 pcs)

Part numbers

Product	Part No. Single pack	Part No. Bulk pack	Description
	51611-01	–	DuoControl CS vertical
	–	51611-53 (6 pcs)	DuoControl CS vertical 8 BPK 6
	–	51611-54 (6 pcs)	DuoControl CS vertical 10 BPK 6
	–	51630-51 (6 pcs)	DuoControl vertical 8 BPK 6
	51621-01	–	DuoControl CS horizontal
	–	51621-54 (6 pcs)	DuoControl CS horizontal 10 BPK 6
	52412-01	–	MonoControl CS
	–	52412-63 (12 pcs)	MonoControl CS 8 BPK 12
	–	52412-64 (12 pcs)	MonoControl CS 10 BPK 12
	–	52400-51 (12 pcs)	MonoControl 8 BPK 12
	–	52400-52 (12 pcs)	MonoControl 10 BPK 12
	50603-01	–	Gas filter, incl. filter pad
	–	50603-51 (12 pcs)	Gas filter BPK 12, incl. filter pads
	50603-02	–	Gas filter kit, 2 pcs., incl. filter pads
	50681-01	–	Filter pads, 10 pcs., for Gas filter
	50020-00379	–	Angle bracket gas filter
	50212-01	–	Remote indicator DuoC incl. control panel
	50212-03	–	Remote indicator DuoC without control panel

The part numbers for other gas installation accessories and EisEx can be found in the current dealers' catalogue and in Truma Parts in the OEM login at www.truma.com.

Truma Gerätetechnik GmbH & Co. KG
Wernher-von-Braun-Straße 12
85640 Putzbrunn, Germany
Telefon +49 (0)89 4617-2020
customer@truma.com

The right to effect technical modifications is reserved!